



INSTALLATION AND HANDLING OF

ELEVATOR FLAT CABLE SYSTEM AND COMPENSATION WEIGHT CW

Installation and handling of Dynofil elevator suspension cables

1. Transport and storage

1.1	Transport of cable drums	page	4
1.2–1.3	Moving cable drums	page	4–5
1.4	Rewinding onto smaller coils	page	6
1.5	Transport and storage of cable coils	page	6

2. Installation instructions for all travelling heights

2.1	Installation positions on shaft wall and car floor	page	7
2.2	Proper use of stripping knife	page	8
2.3	Paying out of cables into the shaft	page	9

3. Installation of Dynofil FL and FM

3.1–3.3	Suspension devices	page	10–12
3.4	Maximum clamping thickness of suspension devices	page	13
3.5	Cable combinations for Dynofil FL	page	14
3.6	Cable combinations for Dynofil FM	page	14
3.7	Securing the suspension devices to the shaft wall	page	15
3.8	Fixing several adjacent suspension devices	page	16
3.9	Fixing the suspension device on the elevator car	page	16
3.10	Installation positions of suspension devices for Dynofil FL	page	17–18
3.11	Installation positions of suspension devices for Dynofil FM	page	19–20
3.12	Minimum loop spacing for cable combinations	page	21

4. Installation of Dynofil FH and Compensation weight CW

4.1	Suspension device	page	22
4.2–4.3	Securing the suspension device	page	23
4.4–4.5	Preparations for cable installation	page	24–27
4.6	Cable combinations with wire ropes	page	28
4.7	Combinations with different cable widths	page	29
4.8	Installation of multiple suspension devices side by side	page	30
4.9	Installation positions of suspension devices for Dynofil FH	page	31–32
4.10	Installation position of Compensation weight CW	page	33

Accessories	page	34
--------------------	------	----

Warranty and Safety information:

Failure to follow these procedures will not only invalidate product warranty, but could endanger public safety.

Using other than strongly recommended Daetwyler suspension devices, Hilti fixation material or equivalent hardware could seriously jeopardize the safety of your installation and void any warranty.

1. Transport and storage

Panel is nailed
securely
to drum flanges



Drum flange

Wooden panel

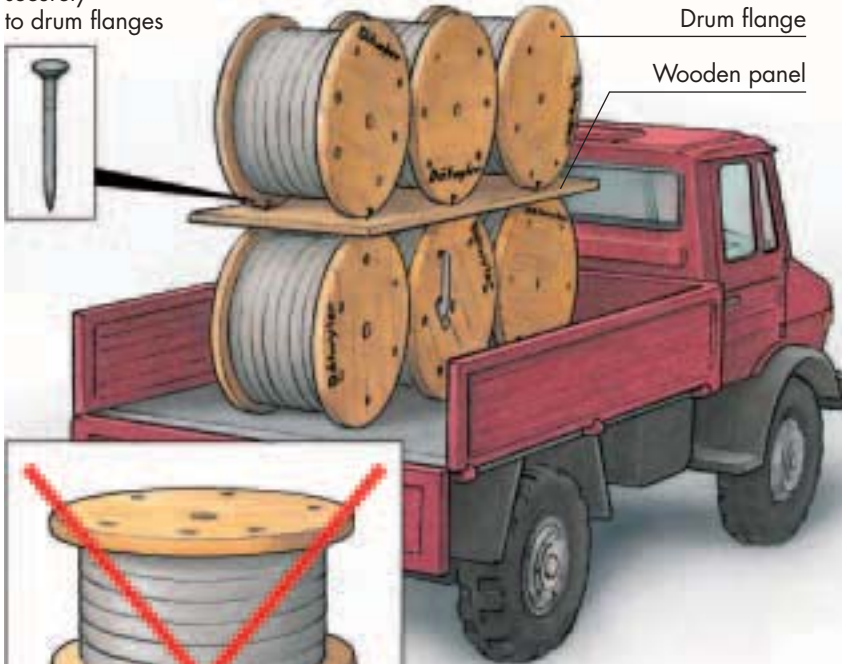

1.1

Transport of cable drums

Whether on vehicles, railway wagons or in interim storage areas, cable drums must always be positioned on the two drum flanges.

The cable on the drum must be protected with a foil covering.

If cable drums are stacked on top of each other, stable wooden panels are to be placed between the individual layers.

The wooden panels must always be nailed securely to the flanges of the cable drums underneath.

1.2

Moving cable drums

If Dynofil cable drums are moved manually, they must only be moved in the direction of the arrow.

The direction arrow is printed on both drum flanges.

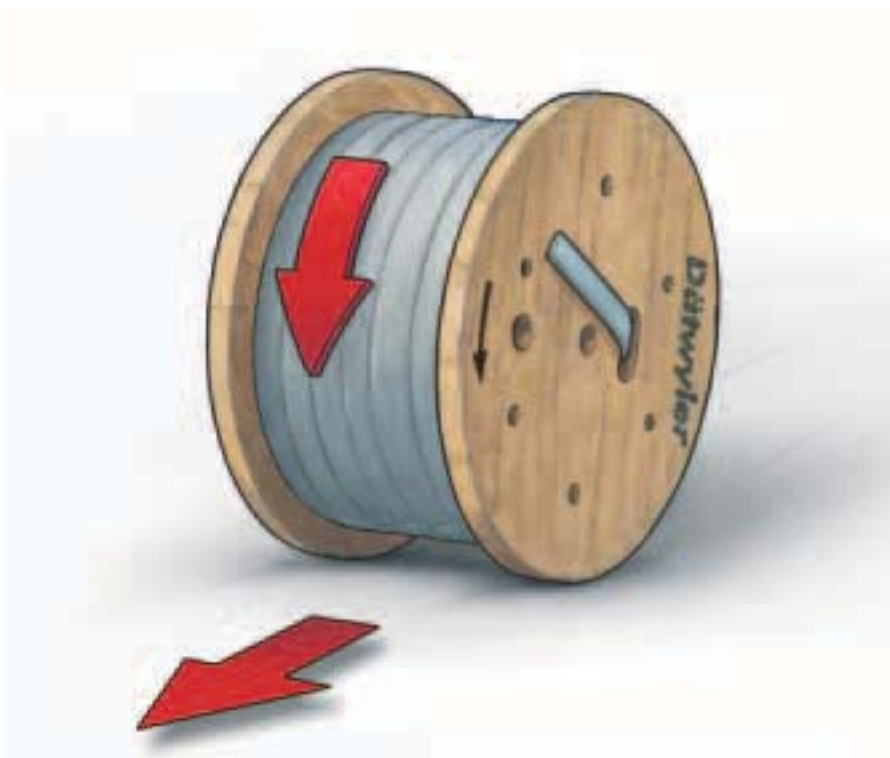



1.3 Moving cable drums by fork-lift

The cable drums must always be placed crossways on the forks of the truck.



1. Transport and storage

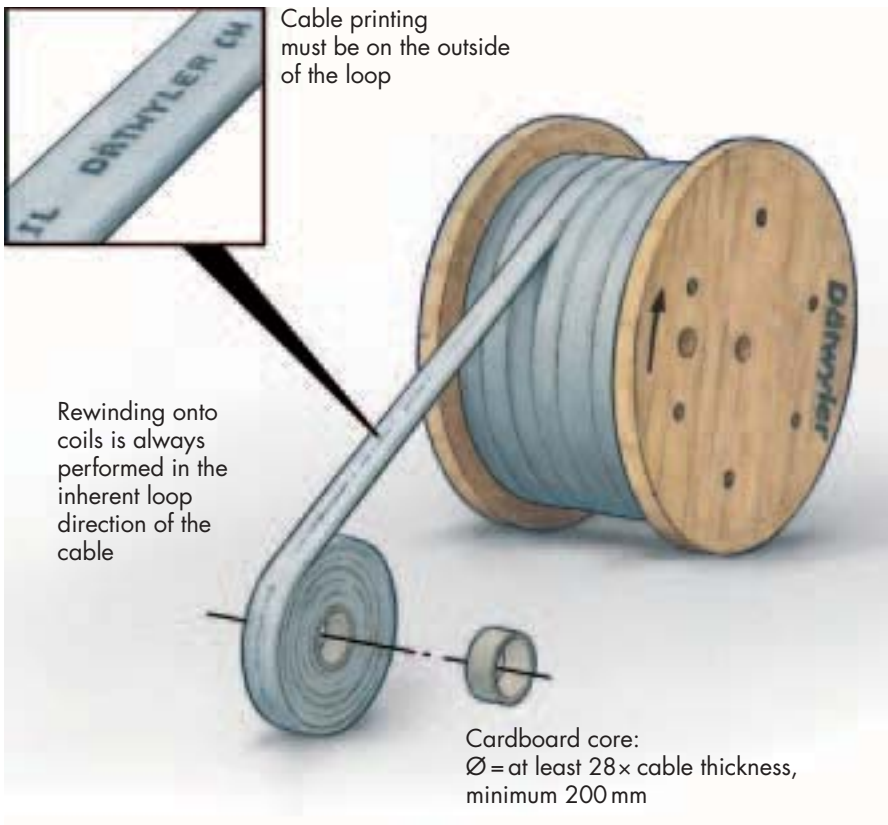

1.4 Rewinding onto smaller coils

Cable coils up to approx. 50 m (165 feet).

For transporting small cable units (e.g. on building sites, in temporary storage areas, etc.) Dynofil cables must be rewound onto a cardboard core.

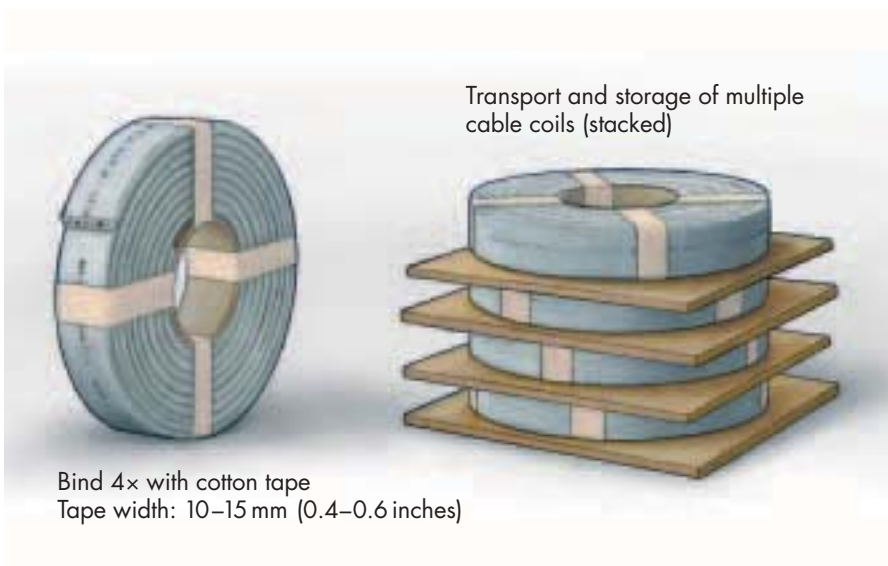

1.5 Transport and storage of cable coils

For transport and storage the cable coils should be tied with 4 fabric tapes.
Tape width: 10–15 mm (0.4–0.6 inches)

If cable coils are stacked for transport or storage, plywood boards should always be placed between the individual coils.

2. Installation instructions for all travelling heights

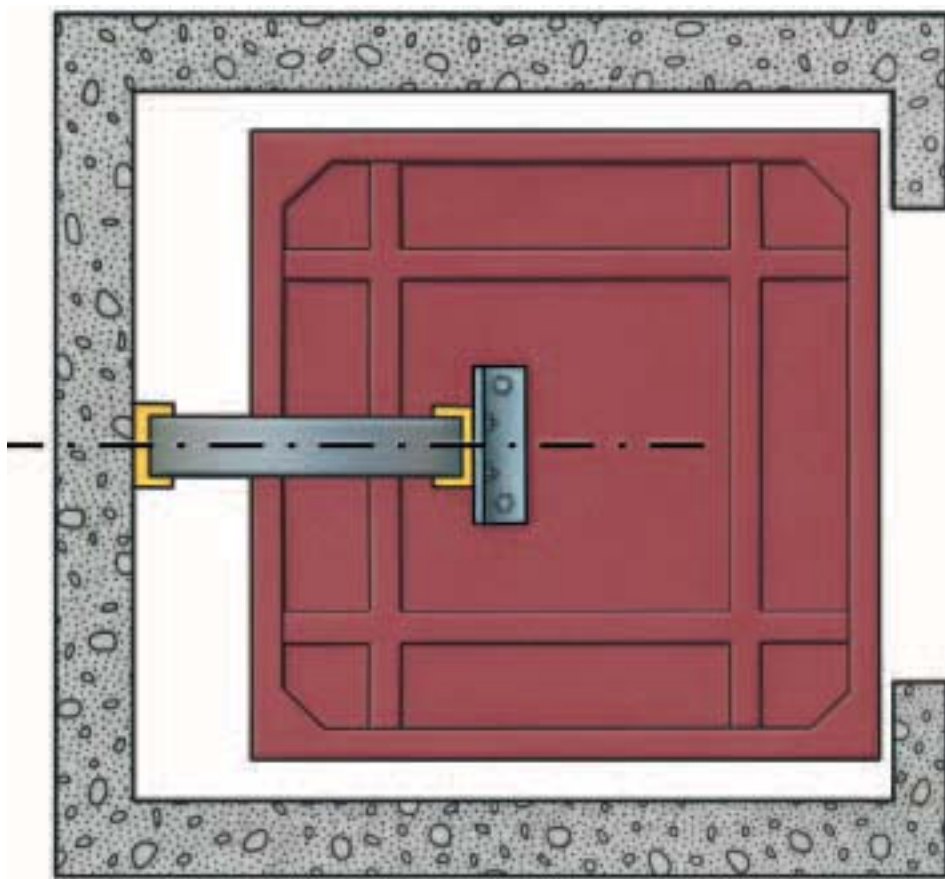

2.1 Installation positions on shaft wall and car floor

The installation positions on the wall and car floor must be precisely aligned.

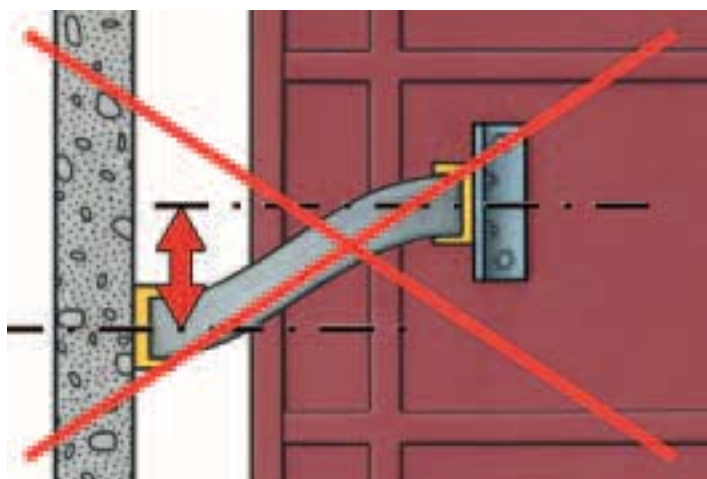

2. Installation instructions for all travelling heights

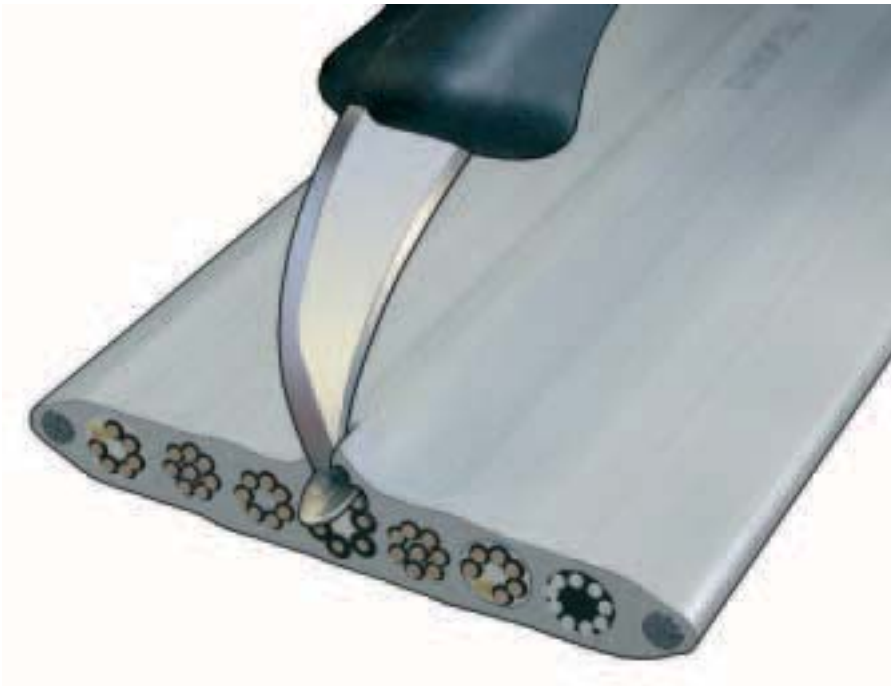

2.2 Proper use of stripping knife

Stripping knife (Part No. 163358)
for safe dismantling of the cable sheath.



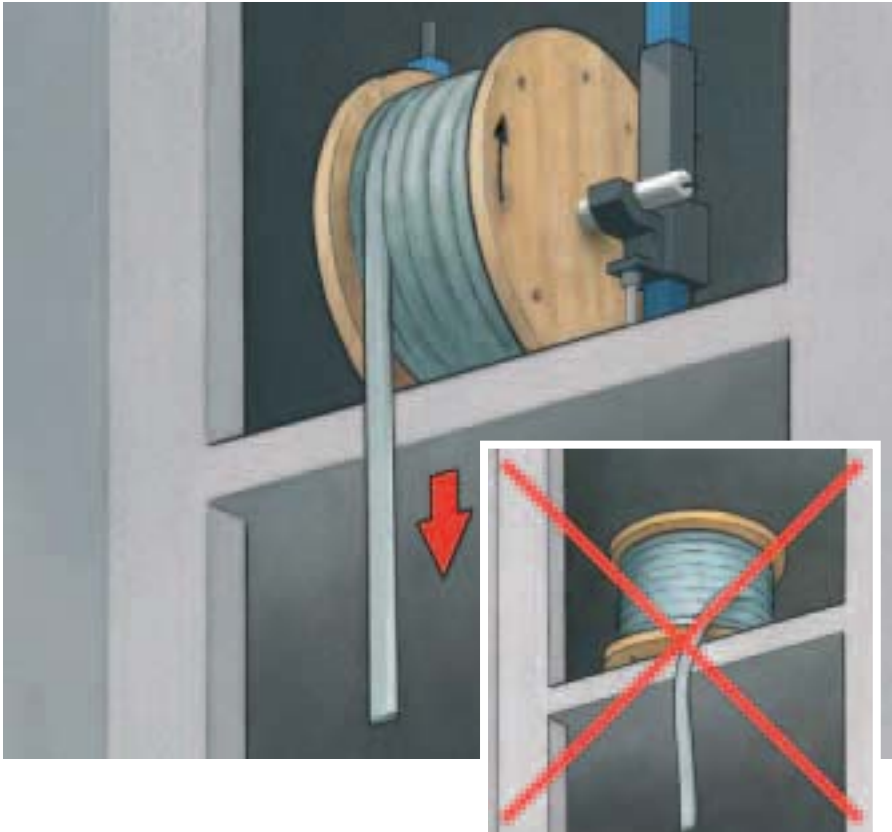

2.3 Paying out of cables into the shaft

All Dynofil elevator suspension cables (FL, FM, FH) can be paid out from the top or drawn up from the bottom.

The Compensation weight CW has always to be paid out from the bottom!

Cable must always be paid out in the direction parallel to the drum flanges. On no account should the drum be laid on its side and the cable be removed around the flanges. This introduces twisting of the cable.

It is imperative to maintain the inherent loop direction of the cable, i. e. the printing on the cable sheath should always be on the outside of the loop.

If guide pulleys are used for unreeling, the minimum pulley diameter is $28 \times$ cable thickness.

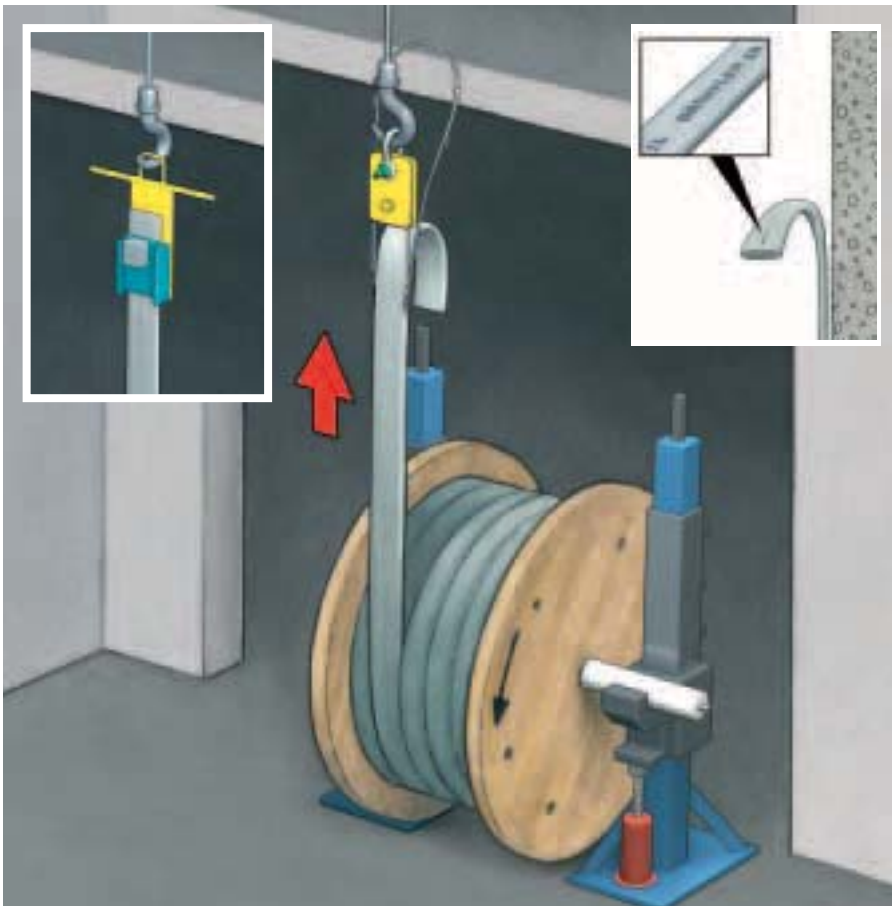

3. Installation of Dynofil FL and FM

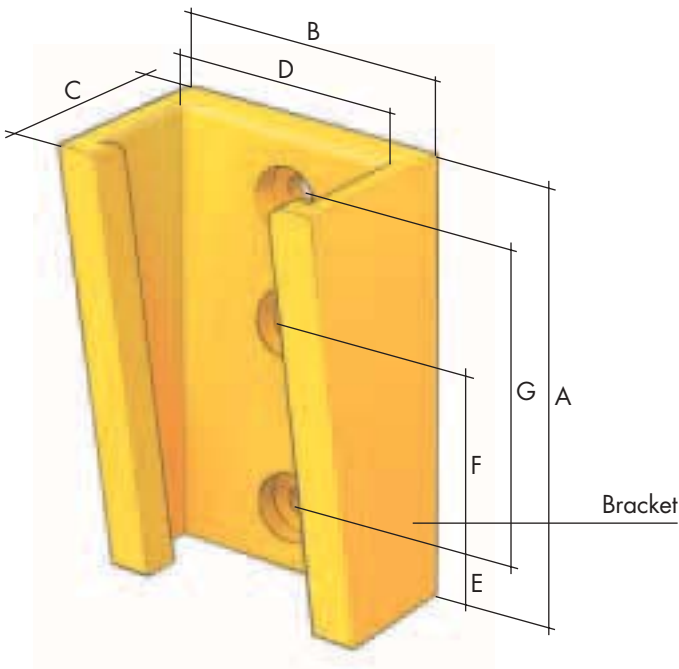
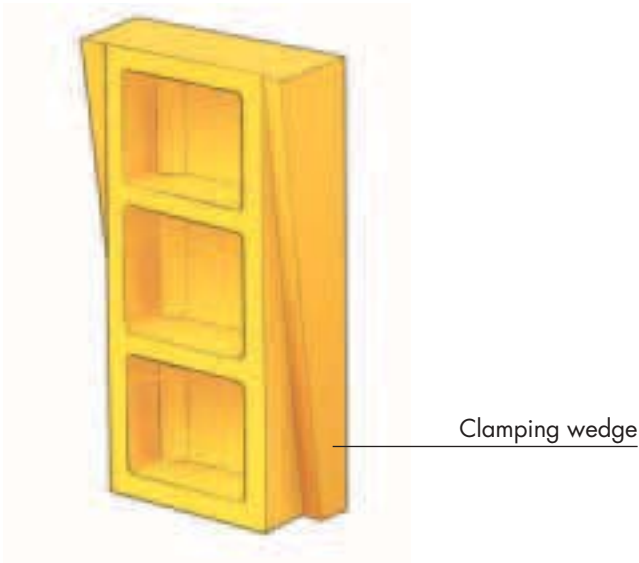

3.1
Suspension device LZ 1006
Color: yellow
(Part No. 178645)

Color: grey
(Part No. 179813)

The cable width, number of cables (combinations) and travelling height determine the selection of cable suspension.

Dynofil elevator suspension cables with a width $b \leq 55$ mm (2.17 inches) are normally installed with the nylon suspension device LZ 1006. This is easy to handle and ensures correct cable installation.

Maximum clamping thickness of suspension devices

In addition to cable width and travelling height, the number of cables (cable combinations) to be mounted determine the selection of the correct suspension device(s).

To this end, please note the maximum clamping thickness of the individual suspension parts.

Clamping range for LZ 1006:
 Max. 14 mm (0.55 inches)

Dimensions

- A = 100 mm (3.94 inches)
- B = 65 mm (2.56 inches)
- C = 47 mm (1.85 inches)
- D = 55 mm (2.17 inches)
- E = 13.5 mm (0.53 inches)
- F = 43 mm (1.69 inches)
- G = 73 mm (2.87 inches)



Hilti HPS 6/5



Bolt M6x20

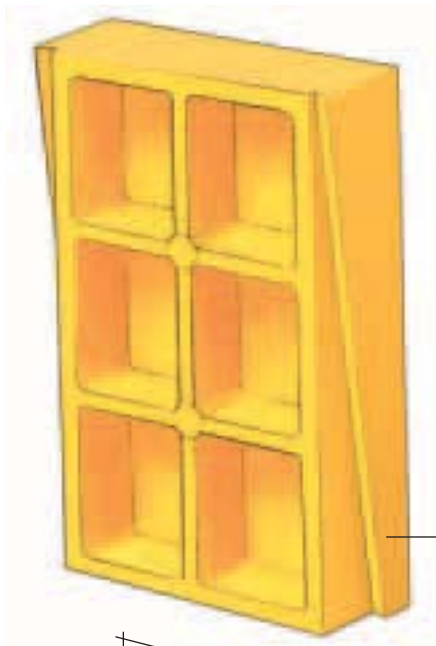

Clamping wedge

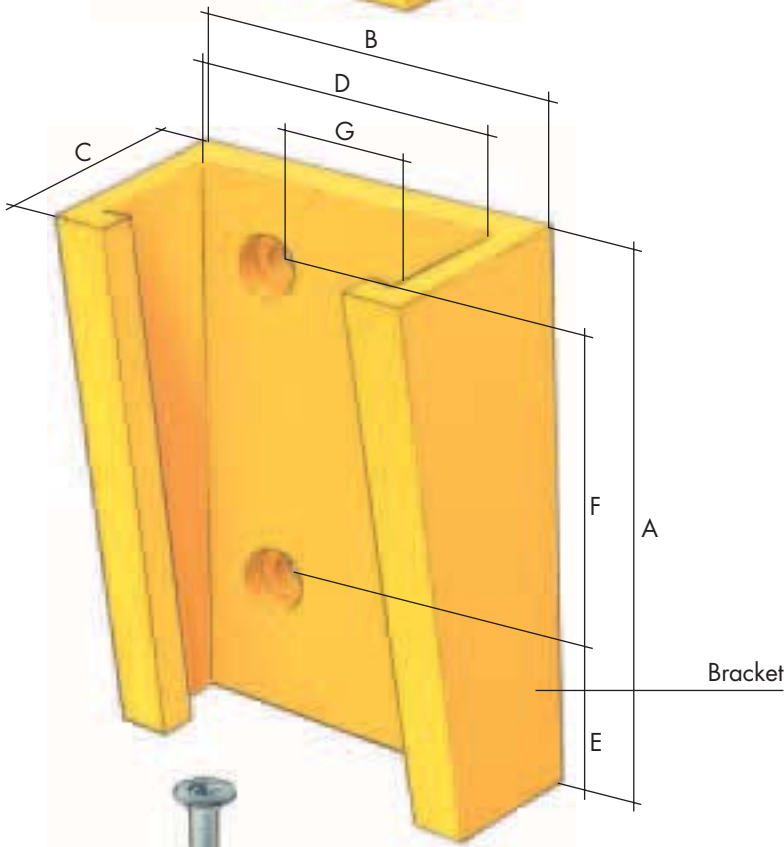

Bracket



Hilti HPS 6/5



Bolt M6x20

3.2
Suspension device LZ 1009
Color: yellow
(Part No. 175159)

Color: grey
(Part No. 179814)

The cable width, number of cables (combinations) and travelling height determine the selection of cable suspension.

Dynofil elevator suspension cables with a width $b \leq 56-79$ mm (2.2-3.11 inches) are normally installed with the nylon suspension device LZ 1009. This is easy to handle and ensures correct cable installation.

Maximum clamping thickness of suspension devices

In addition to cable width and travelling height, the number of cables (cable combinations) to be mounted determine the selection of the correct suspension device(s).

To this end, please note the maximum clamping thickness of the individual suspension parts.

Clamping range for LZ 1009:
 Max. 15 mm (0.59 inches)

Dimensions

- A = 120 mm (4.72 inches)
- B = 92 mm (3.62 inches)
- C = 51.5 mm (2.03 inches)
- D = 79 mm (3.11 inches)
- E = 27 mm (1.06 inches)
- F = 73 mm (2.87 inches)
- G = 40 mm (1.57 inches)

3. Installation of Dynofil FL and FM

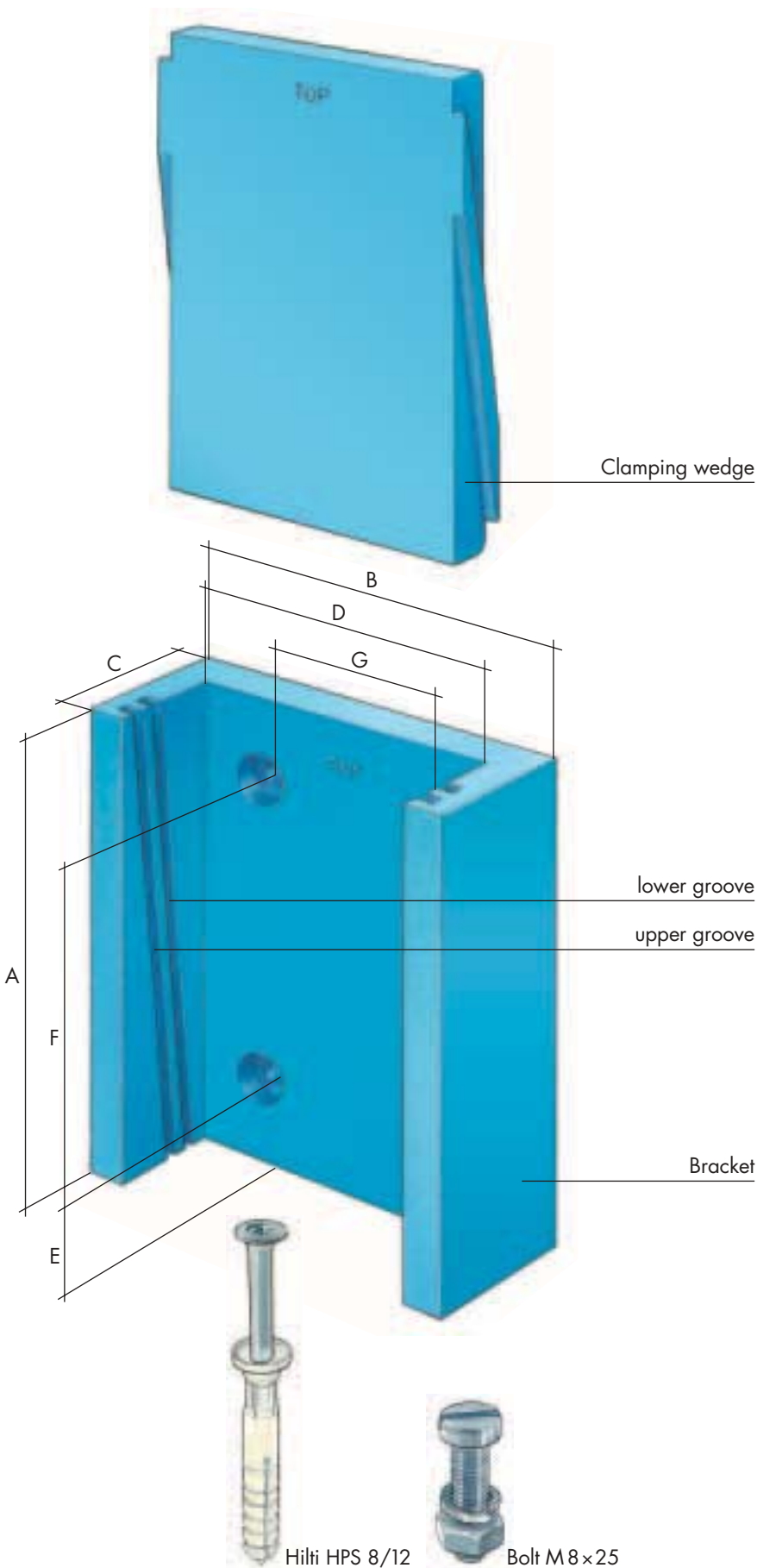

3.3 Suspension device LZ 1010 (Part No. 163354)

The cable width, number of cables (combinations) and travelling height determine the selection of cable suspension.

Dynofil elevator suspension cables with a width $b = 80\text{--}100\text{ mm}$ (3.15–3.94 inches) are normally installed with the aluminium suspension device LZ 1010.

Maximum clamping thickness of suspension devices

In addition to cable width and travelling height, the number of cables (cable combinations) to be mounted determine the selection of the correct suspension device(s).

To this end, please note the maximum clamping thickness of the individual suspension parts.

Clamping range for LZ 1010:
Lower groove max. 14 mm (0.55 inches)
Upper groove max. 22 mm (0.87 inches)

Dimensions

- A = 140 mm (5.51 inches)
- B = 120 mm (4.72 inches)
- C = 50 mm (1.97 inches)
- D = 100 mm (3.94 inches)
- E = 22 mm (0.87 inches)
- F = 96 mm (3.78 inches)
- G = 60 mm (2.36 inches)

3.4 Maximum clamping thickness of suspension devices

In addition to cable width and travelling height, the number of cables (cable combinations) to be mounted determine the selection of the correct suspension device(s).

To this end, please note the maximum clamping thicknesses of the individual suspension parts.

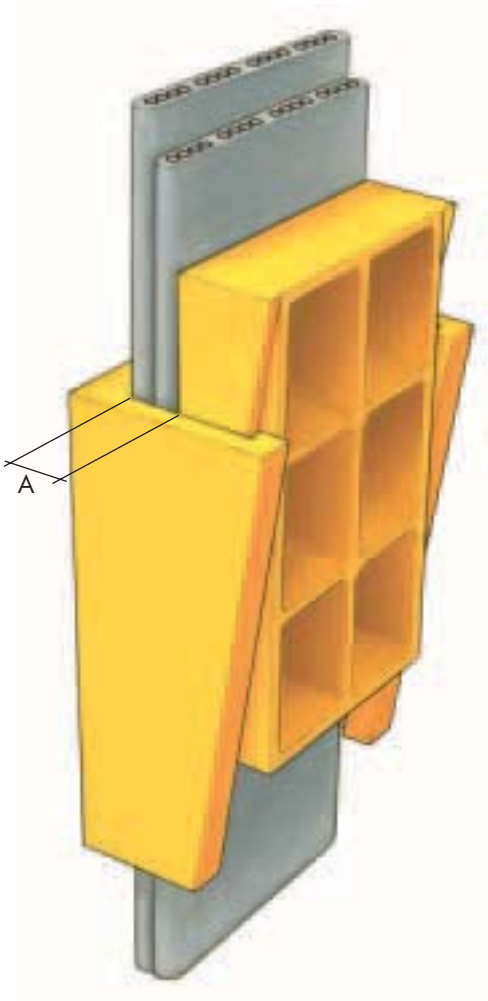

Clamping range for LZ 1006:
A = max. 12 mm (0.47 inches)

Clamping range for LZ 1009:
A = max. 15 mm (0.60 inches)

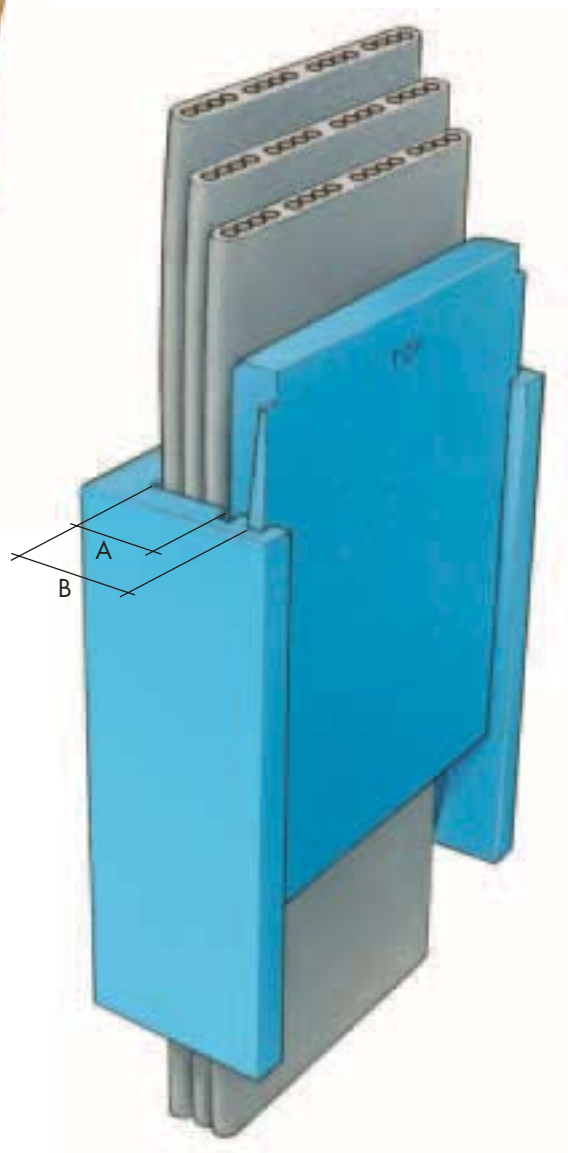

Clamping range for LZ 1010:
lower groove
A = max. 14 mm (0.55 inches)

upper groove
B = 14–22 mm (0.55–0.87 inches)

3. Installation of Dynofil FL and FM

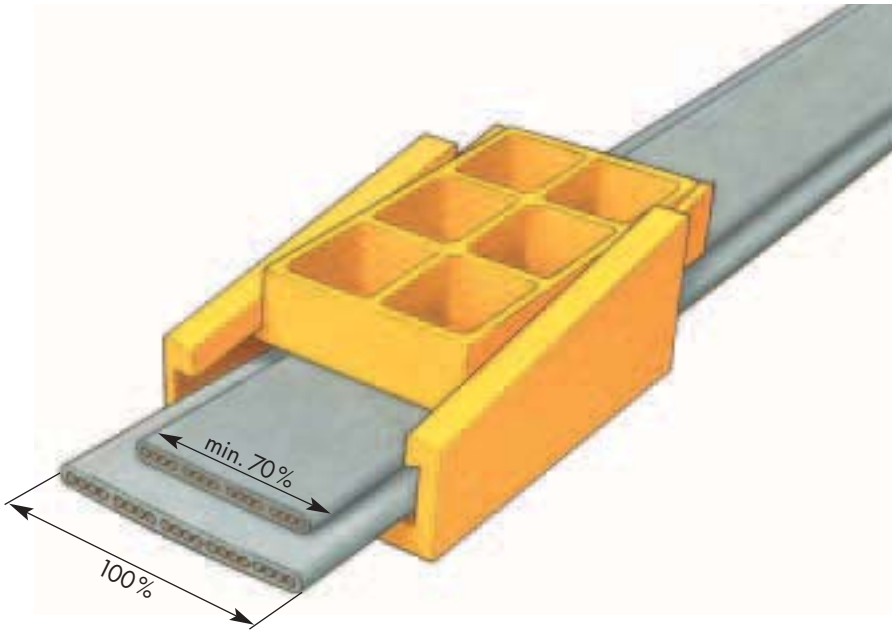

3.5 Cable combinations for Dynofil FL

A maximum of 2-3 cables of different widths can be installed with one suspension device.

The narrowest width cable must be minimum 70% of the widest cable.

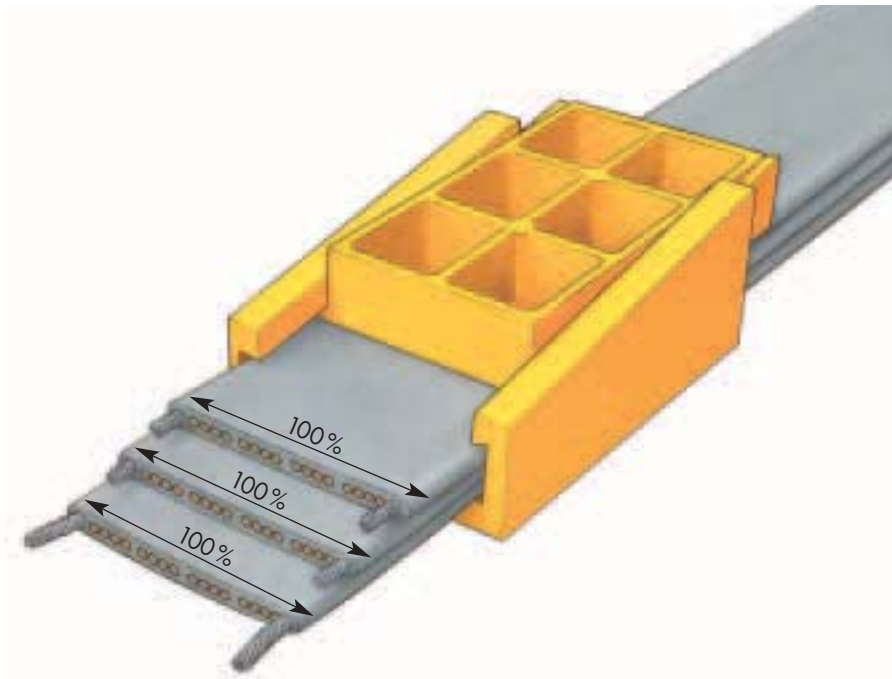

3.6 Cable combinations for Dynofil FM

Only combinations of cables with the same width are permissible.

3.7 Securing the suspension devices to the shaft wall

The instructions apply to
LZ 1006, LZ 1009 and LZ 1010:

Fix bracket with Hilti HPS 6/5 or
HPS 8/12 or equivalent.

The dowel is tapped home with a
hammer and then tightened with
a screwdriver.

Minimum concrete strength required:
 $\beta_w = 20 \text{ N/mm}^2$

Draw in cable.

Insert wedge from above.

Tap wedge home lightly with a hammer
until the cable(s) is/are securely fixed.

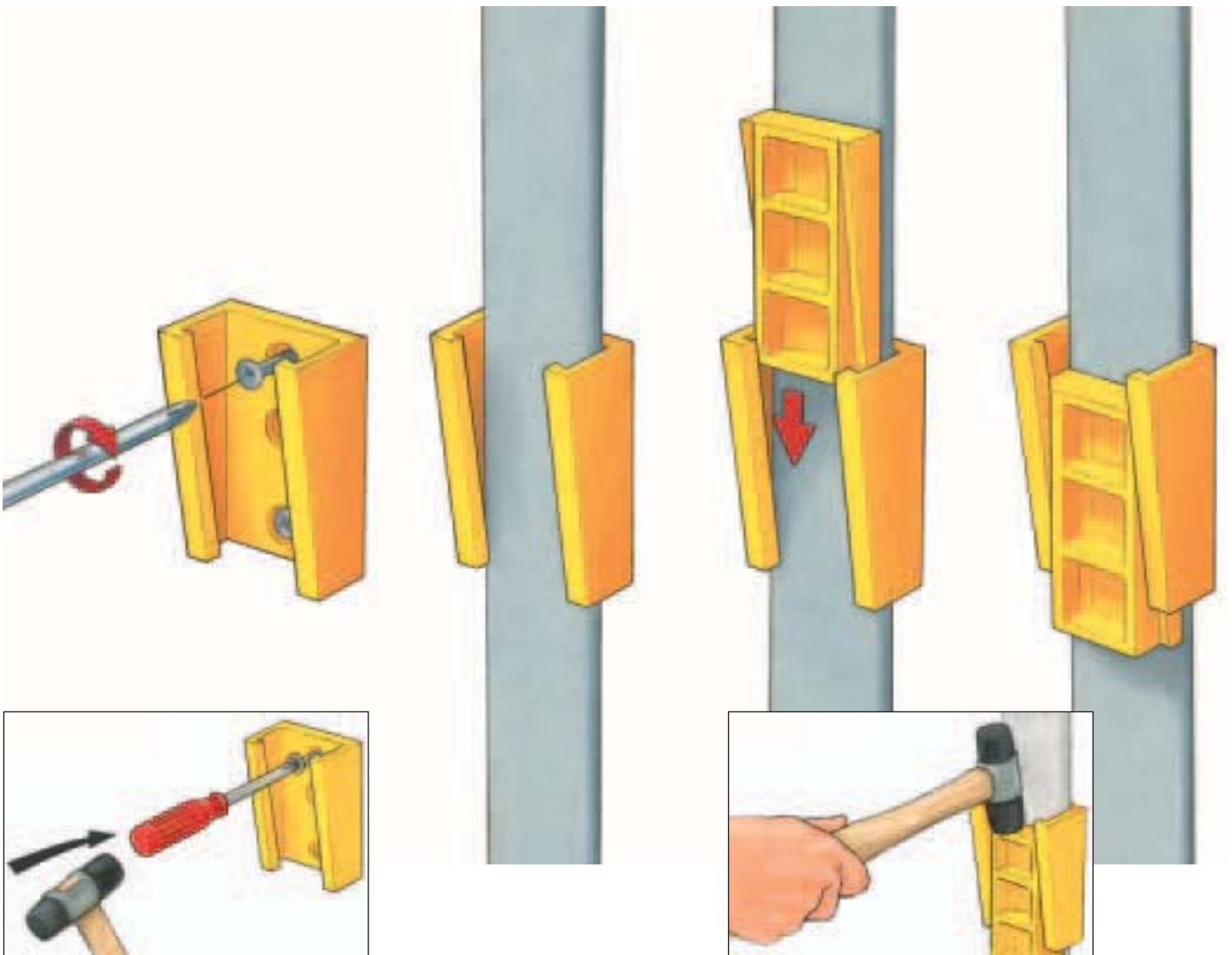

Tap home dowel and tighten

Insert wedge and tap home lightly

3. Installation of Dynofil FL and FM

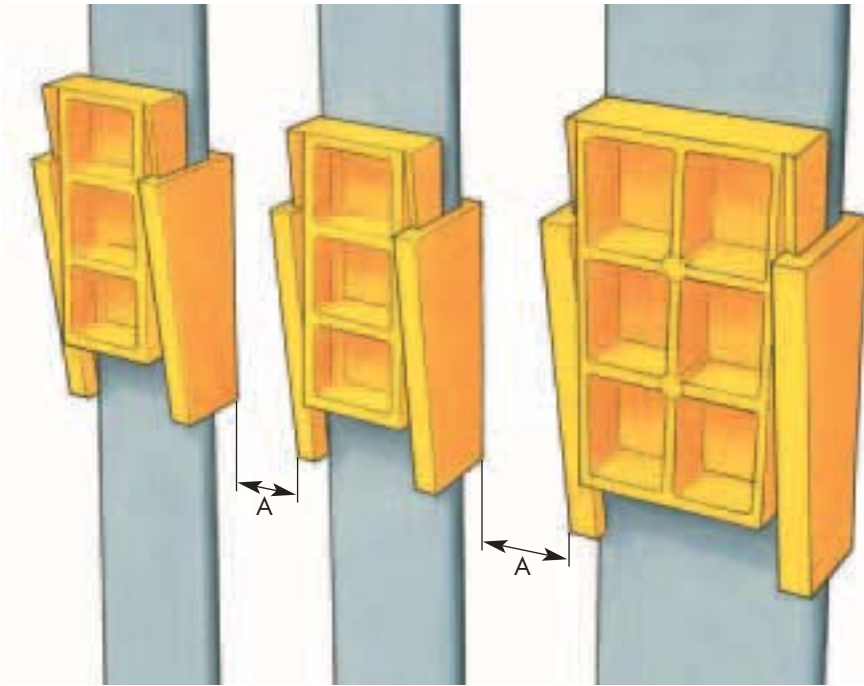

3.8 Fixing several adjacent suspension devices

If a number of suspension devices (LZ 1006, LZ 1009 and LZ 1010) are mounted side by side, the minimum spacing between them is 50 mm (2 inches).

A = min. 50 mm (2 inches)



3.9 Fixing the suspension device on the elevator car

Fix bracket with screw M6 or M8 to the relevant installation device.

Draw in cable.

Insert wedge from above and tap home lightly with hammer.

M6 for LZ 1006 and LZ 1009, M8 for LZ 1010



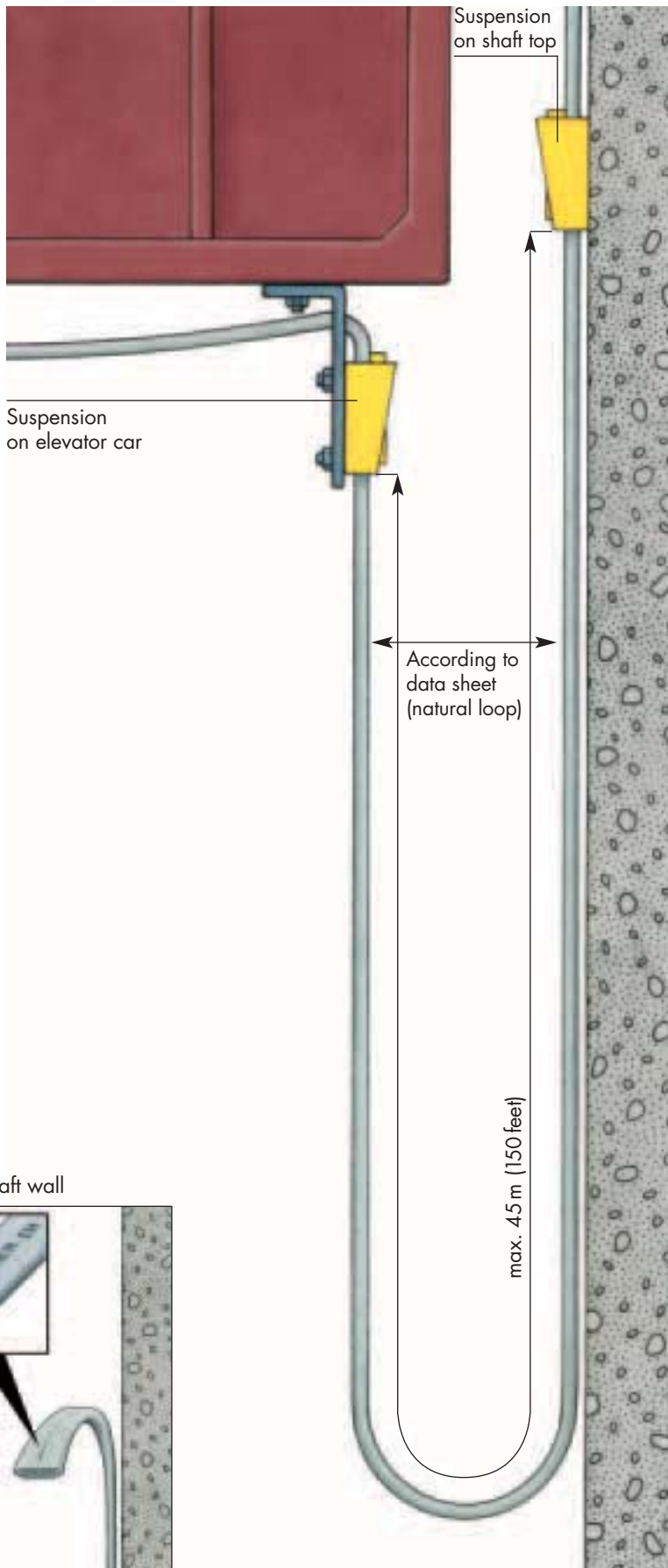

3.10
Installation positions
of suspension
devices for Dynofil FL

3.10.1
Dynofil FL
Travelling height
up to 40 m (130 feet)

Free suspension length
max. 45 m (150 feet)

Permissible suspensions:
 LZ 1006, LZ 1009, LZ 1010

Pressing to shaft wall

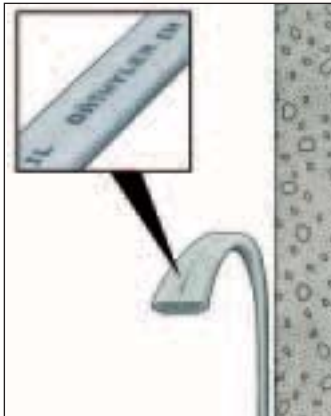

3. Installation of Dynofil FL and FM

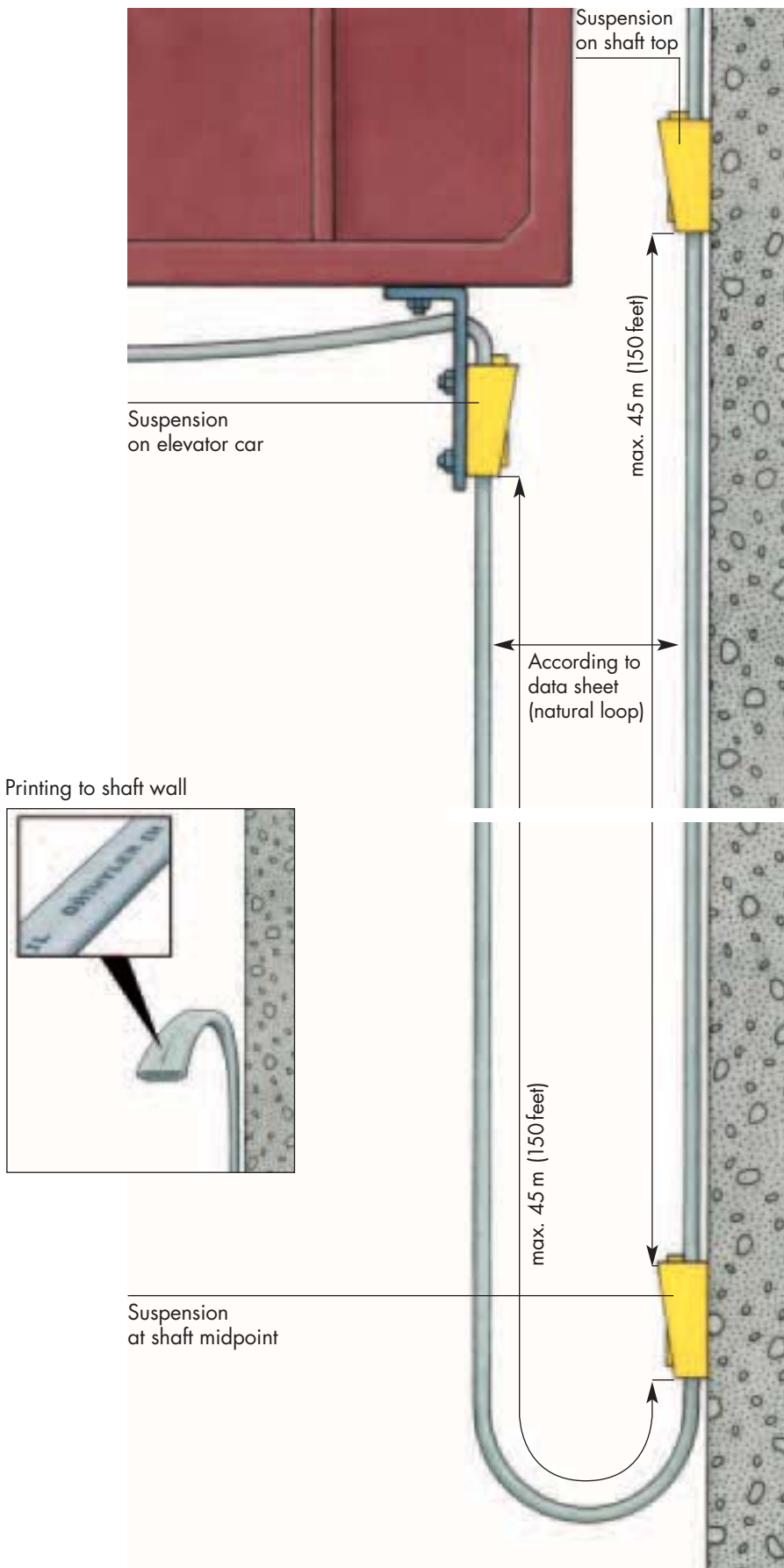

3.10.2
Dynofil FL
Travelling height
up to 80 m (260 feet)

Free suspension length
max. 45 m (250 feet)

Permissible suspensions:
LZ 1006, LZ 1009, LZ 1010

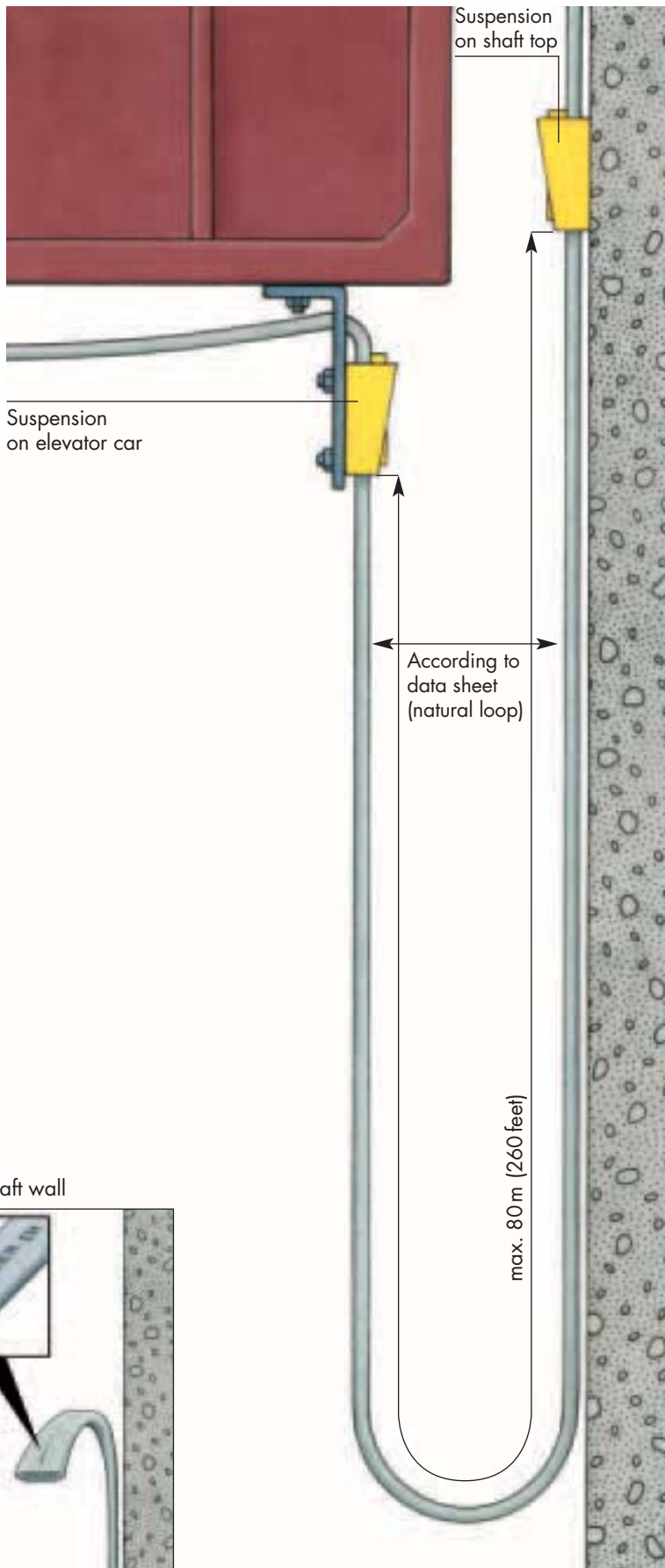

3.11
Installation positions
of suspension
devices for Dynofil FM

3.11.1
Dynofil FM
Travelling height
up to 75 m (245 feet)

Free suspension length
max. 80 m (260 feet)

Permissible suspensions:
 LZ 1006, LZ 1009, LZ 1010

Pressing to shaft wall

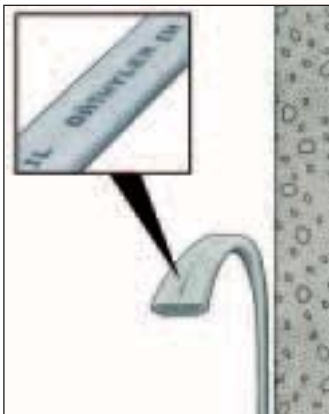

3. Installation of Dynofil FL and FM

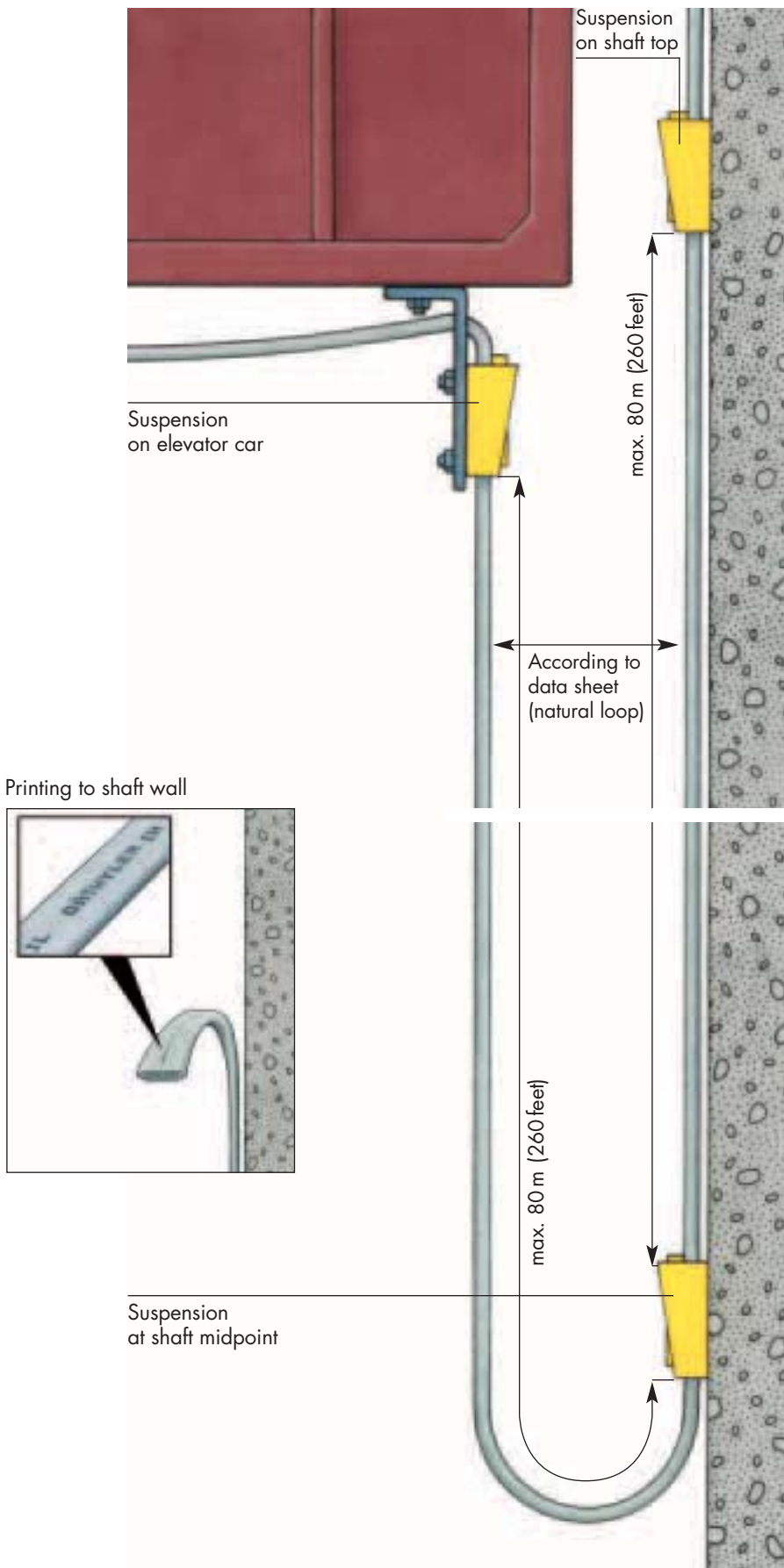

3.11.2
Dynofil FM
Travelling height
up to 150 m (495 feet)

Free suspension length
max. 80 m (260 feet)

Permissible suspensions:
LZ 1006, LZ 1009, LZ 1010

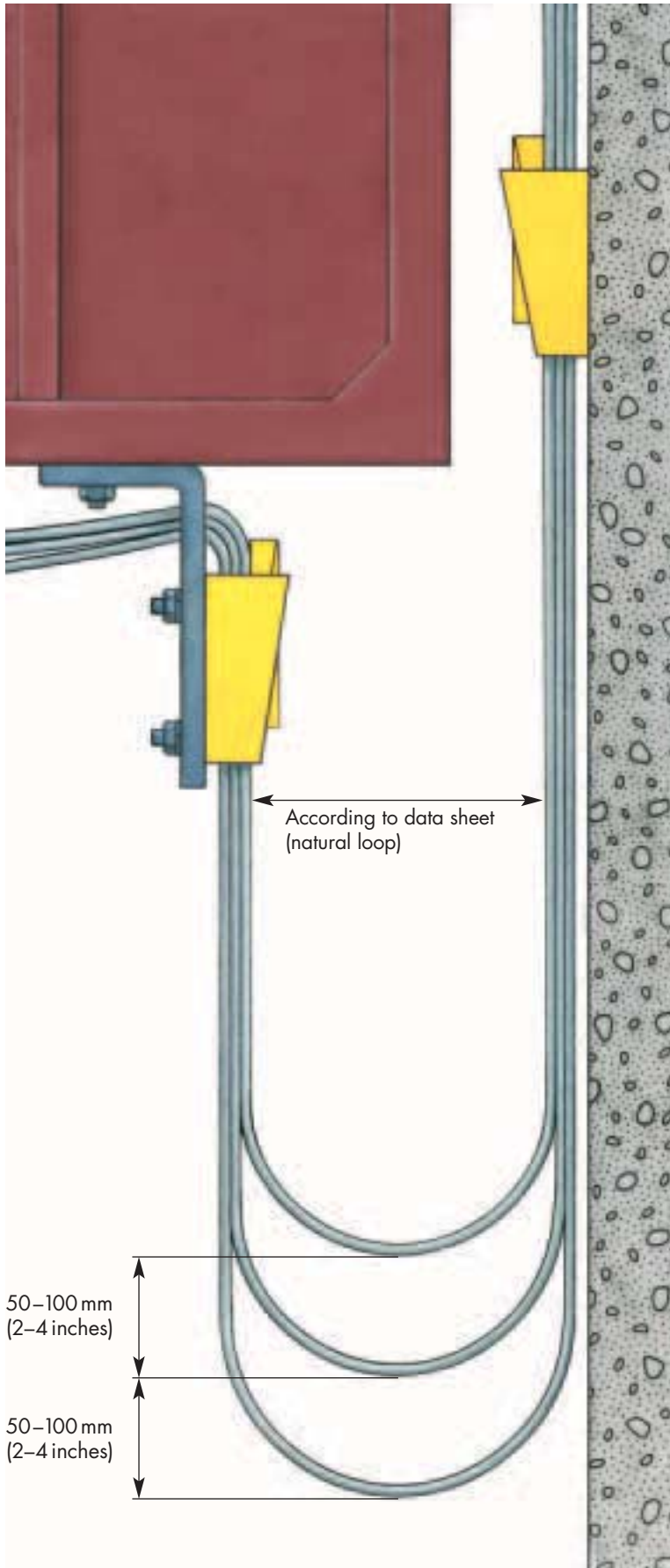

3.12
Minimum loop spacing
for cable combinations

Distance between loops
50-100 mm (2-4 inches)

4. Installation of Dynofil FH and Compensation weight CW

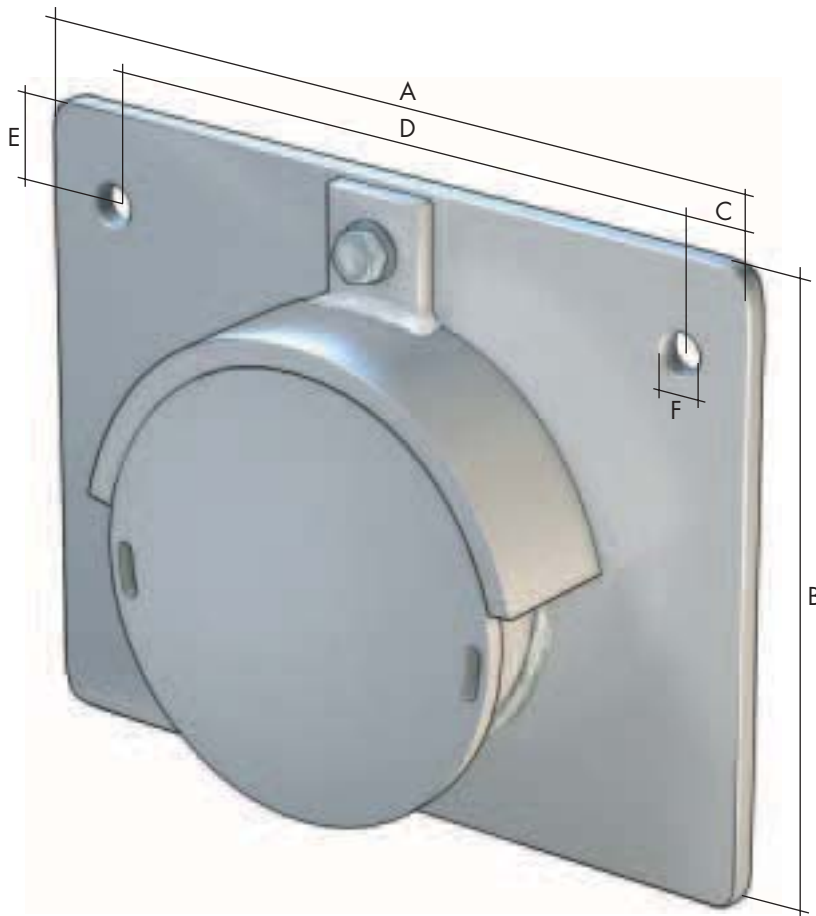

4.1 Suspension device LZ 4001 (Part No. 184606)

The steel suspension device LZ 4001 is normally used for a maximum of 2 Dynofil elevator suspension cables or Compensation weight CW.

Dimensions

A	= 220 mm (8.66 inches)
B	= 170 mm (6.69 inches)
C	= 30 mm (1.18 inches)
D	= 160 mm (6.29 inches)
E	= 25 mm (0.98 inches)
F	= 13 mm (0.51 inches)



Bolt M 12 x 40



Hilti HSL-TZ M 8/20



4.2 Securing the suspension device on the shaft wall

The instructions apply to LZ 4001:

Fix LZ 4001 with safety anchor (Hilti HSL-TZ M8/20 or equivalent).
Minimum concrete strength required:
 $\beta_w = 30 \text{ N/mm}^2$

Tap home safety anchor fully with hammer.

Tighten safety anchor with wrench.
Torque = 25 Nm

Expose supporting elements of cable and draw in cable (see 4.4 and 4.5).



Hilti HSL-TZ M8/20 safety anchor



Tap home safety anchor fully and tighten



4.3 Securing the suspension device to the elevator car

The instructions apply to LZ 4001:

Fix LZ 4001 with screw M12 to corresponding installation device.

Expose supporting elements of cable and draw in cable (see 4.4 and 4.5).



Bolt M 12

4. Installation of Dynofil FH and Compensation weight CW



4.4 Preparations for cable installation

4.4.1 Expose steel wire ropes to 700 mm

A1
If the spacing of the steel wire ropes is ≤ 50 mm (2 inches), approx. 1000 mm (40 inches) of wire ropes must be exposed.

A2
If the spacing of the steel wire ropes is 50–100 mm (2–4 inches), approx. 700 mm (28 inches) wire ropes must be exposed.



Crimping sleeves according to table



Alternatively the free steel wire ropes can be clamped with 3 Crosby clips G-450

4.4.2 Fitting crimping sleeves

Select the size of crimping sleeves according to table 4.4.3.

Alternatively the free steel wire ropes can be clamped with Crosby clips G-450.



4.4.3
Form first loop

Draw one end of wire ropes through 1st sleeve.

Compress sleeve according to table.



Alternative to crimping sleeves:
3x Crosby clips G-450 each side



4.4.4
Form second loop

Draw other end of steel wire ropes through 2nd sleeve.

Use tape for parallel fixation.

Compress sleeve according to table.



Compress sleeve according to table

4. Installation of Dynofil FH and Compensation weight CW

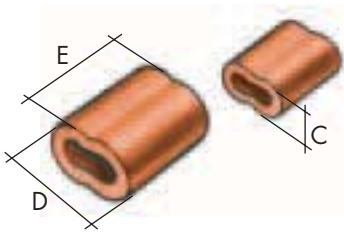

CU crimping sleeves

Ø Steel wire (mm)	Sleeve Part No.	Type	C (mm)	D (mm)	E (mm)	Sleeves per loop	Crimps per sleeve	Section of crimping tool (inch)
2.5	166668	SL 2-3	5.7	9.4	11.4	1+1	2	3/32
3.0	166669	SL 2-4	8.2	12.5	14.6	1+1	2	1/8
3.2	166669	SL 2-4	8.2	12.5	14.6	1+1	2	1/8
4.0	182059	SL 2-5	9.3	15.0	16.1	2+2	3	5/32
5.0	182060	SL 2-6	11.4	17.0	25.7	2+2	3	3/16
6.0	182061	SL 2-7	11.7	18.1	22.2	2+2	3	3/16

Crimping tool Part No. 166667 with different crimps sections

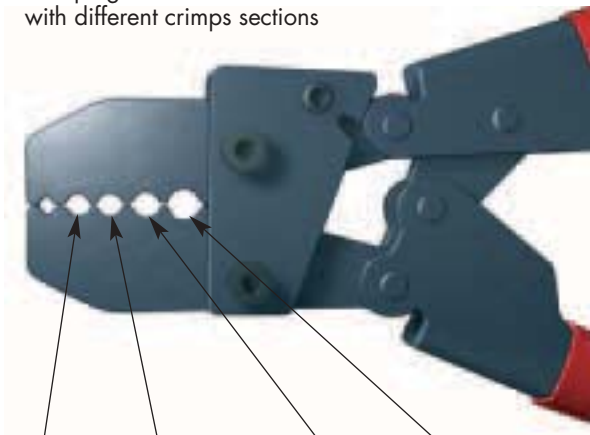

SL 2-3
2.5 mm

SL 2-4
3.0/3.2 mm

SL 2-5
4.0 mm

SL 2-6/SL 2-7
5.0/6.0 mm



Crimping tool has to be close to the end for a correct crimping process

4.4.5 Steel Wire Connection - CU Crimping Sleeve

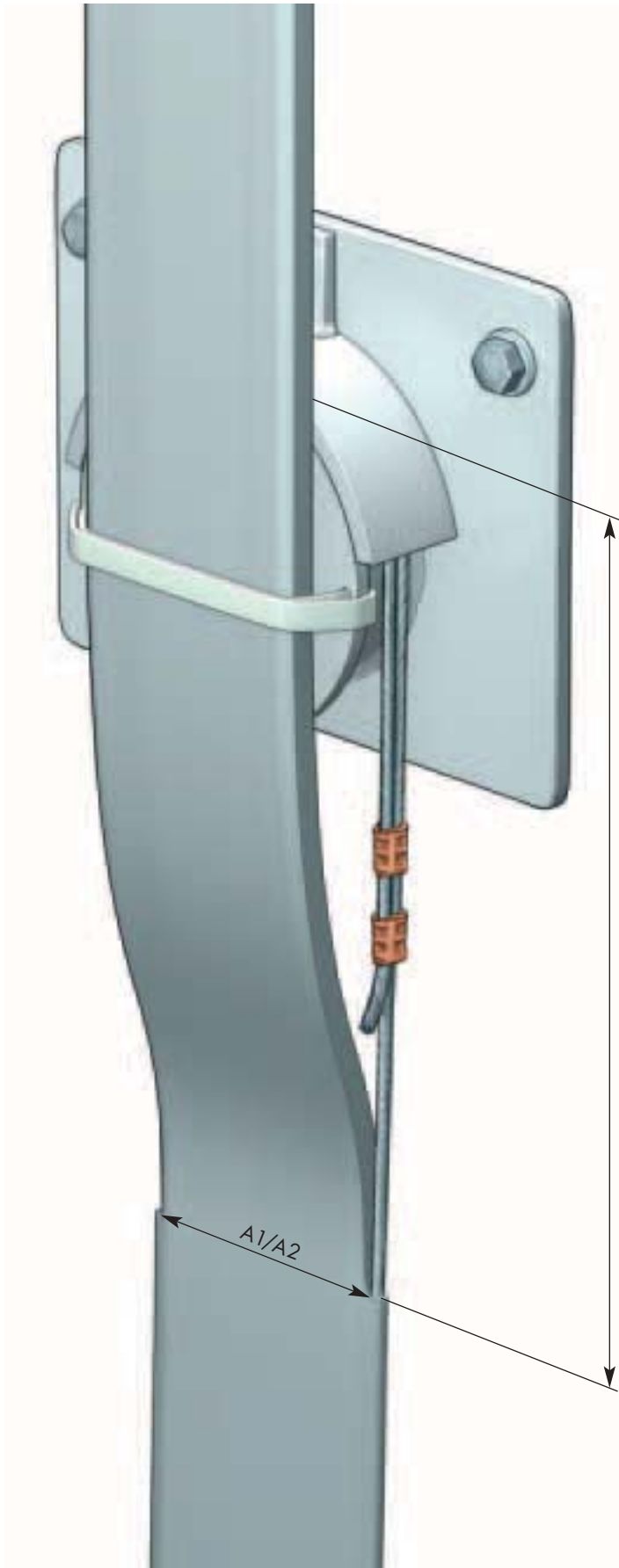

4.5 Preparations for cable installation

A1
If the spacing of the steel wire ropes is ≤ 50 mm (2 inches), the length of the loop (L) is at least 500 mm (20 inches).

A2
If the spacing of the steel wire ropes is bigger than 50 mm (2 inches), the length of the loop (L) must be at least 300 mm (12 inches).

L = loop length

4. Installation of Dynofil FH and Compensation weight CW

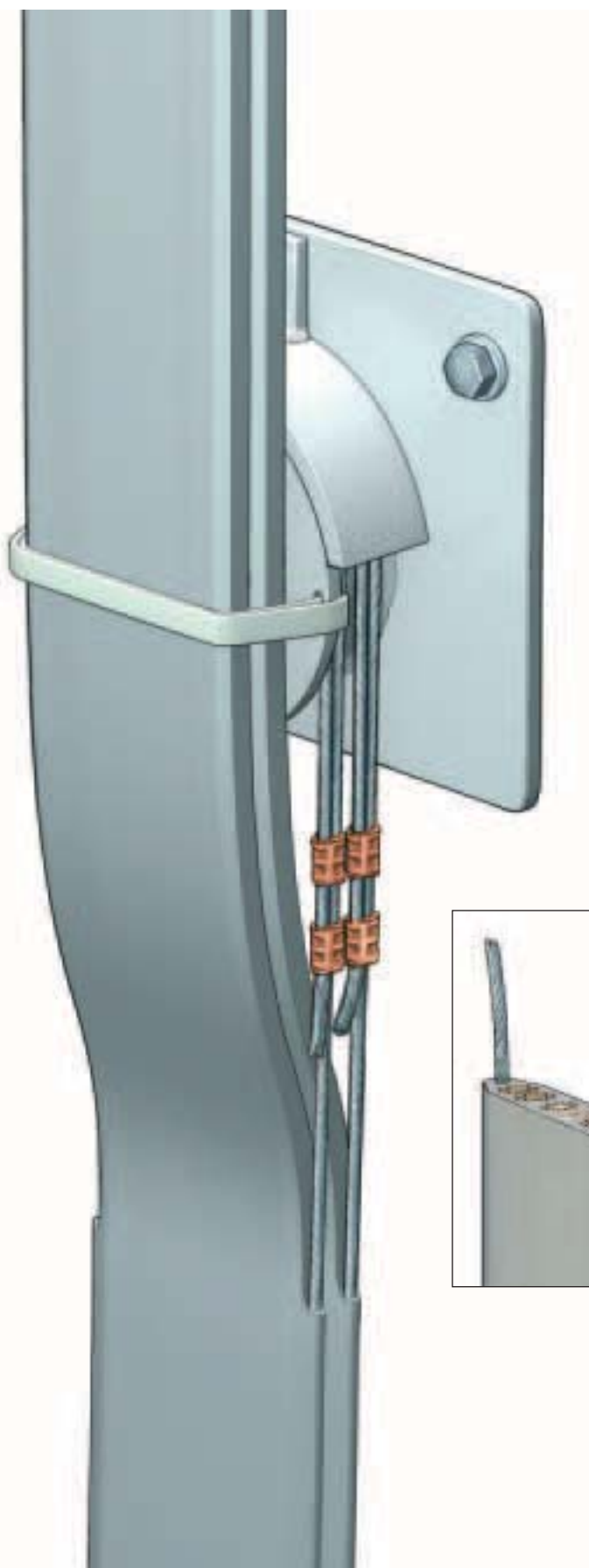

4.6 Cable combinations with wire ropes

A maximum of 2 FH cables or Compensation weight CW can be installed on one suspension device LZ 4001.

The adjacent illustration shows how the cables can be drawn in and suspended.

4.7
Combinations with different
cable widths

Two cables can be combined with different width of supporting member in one suspension device.

The cables should be arranged with regard to their width so that the wire ropes do not affect or damage any of the cables.

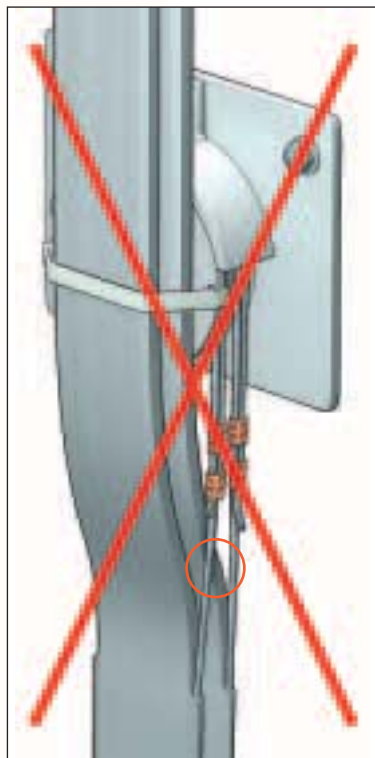
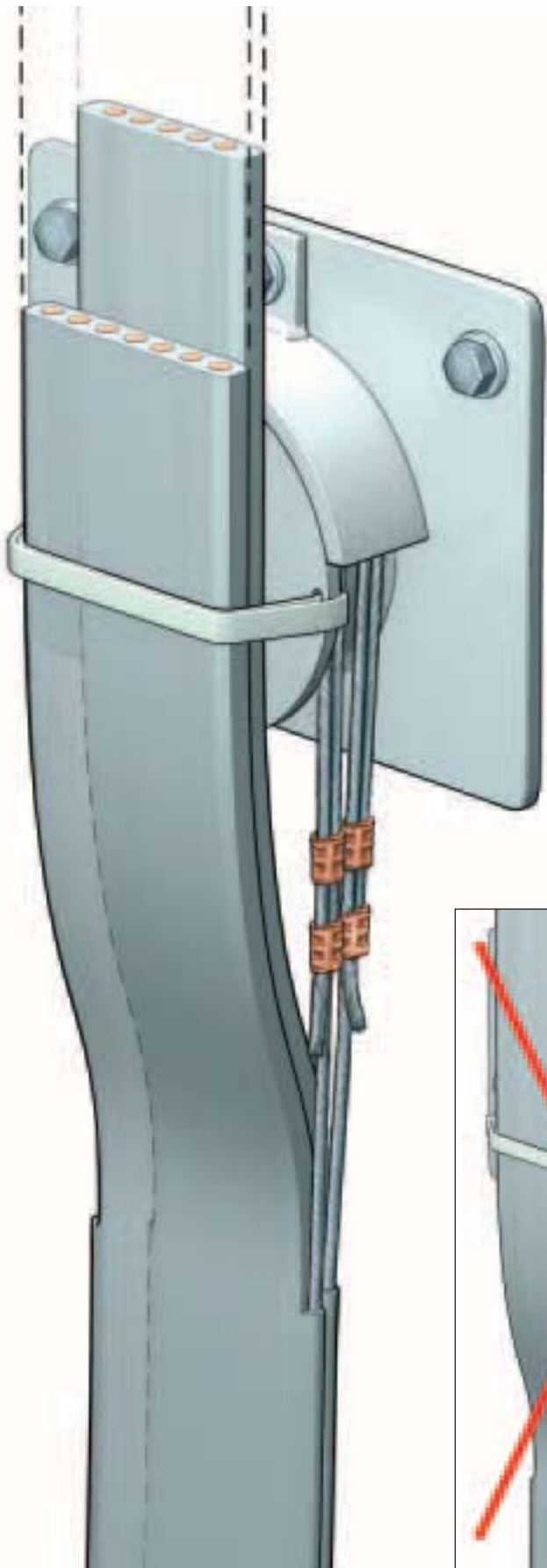

Care should be taken to ensure that supporting members in the narrower cable do not damage the surface of the wider cable.

4. Installation of Dynofil FH and Compensation weight CW

4.8 Installation of multiple suspension devices side by side

If a number of suspension devices (LZ 4001) are installed side by side, the minimum spacing in case of concrete wall from anchor to anchor is 160 mm (6.29 inches).

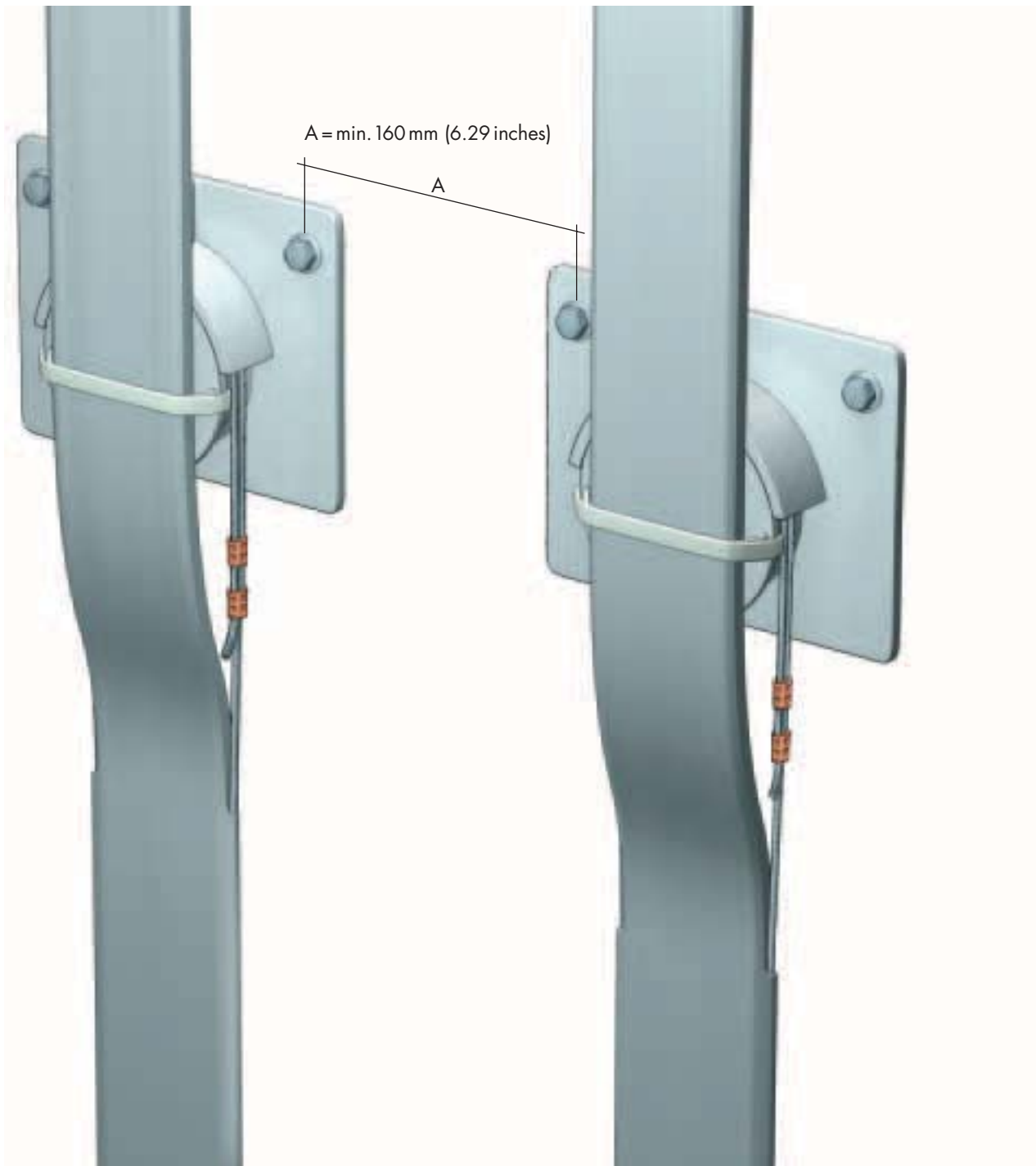

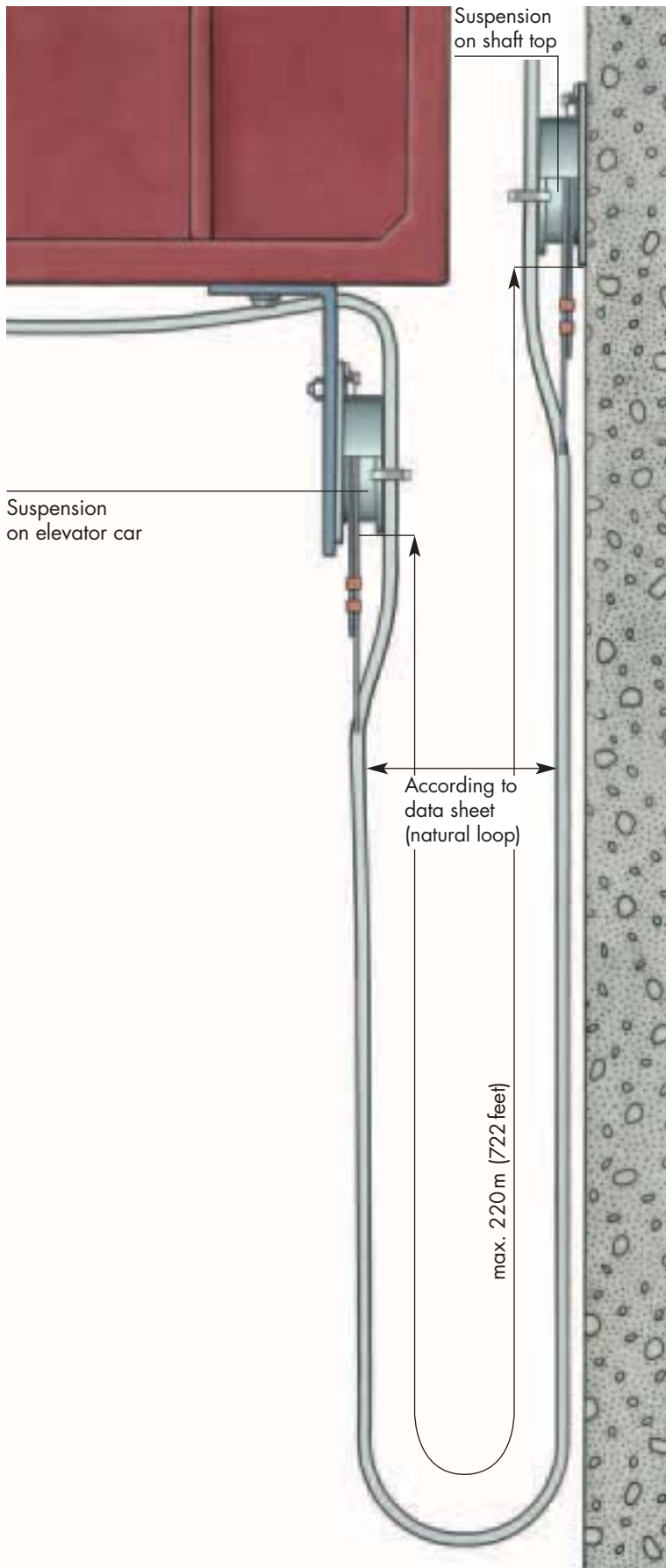

4.9
Installation positions
of suspension
devices for Dynofil FH

4.9.1
Dynofil FH
Travelling height
up to 200 m (656 feet)

Free suspension length
max. 220 m (722 feet)

Permissible suspension devices:
 LZ 4001

4. Installation of Dynofil FH and Compensation weight CW

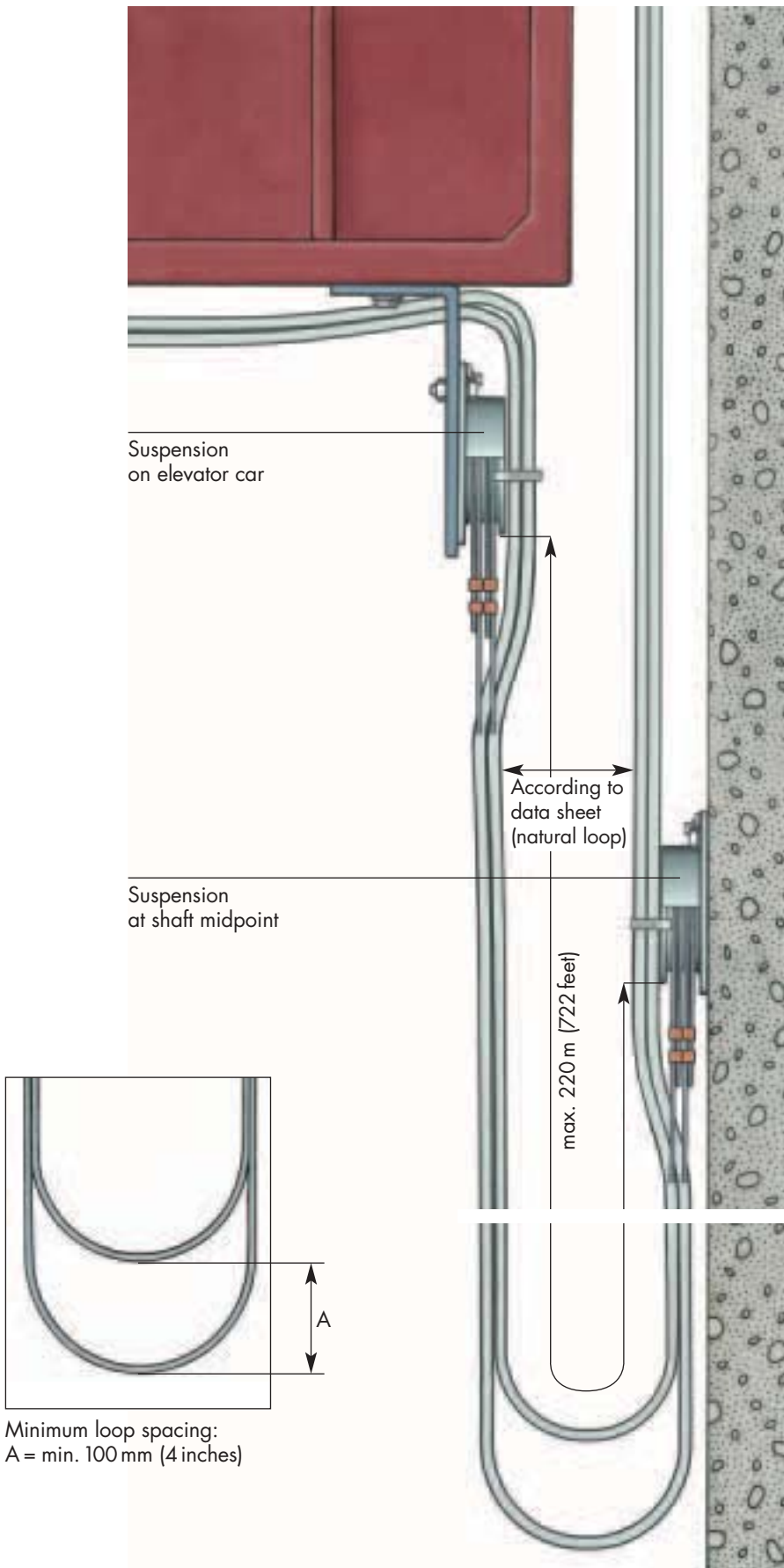

4.9.2 Dynofil FH Travelling height up to 400 m (1312 feet)

**Free suspension length
max. 220 m (722 feet)**

Permissible suspension devices:
LZ 4001

Dynofil travelling cables can be used to form a continuous connection between the elevator car and the top motor room. In this case an additional suspension device is necessary on the shaft top.

Or if preferred:

The connection from shaft midpoint to shaft top is achieved with "fixed wiring". In this case a junction box is required.

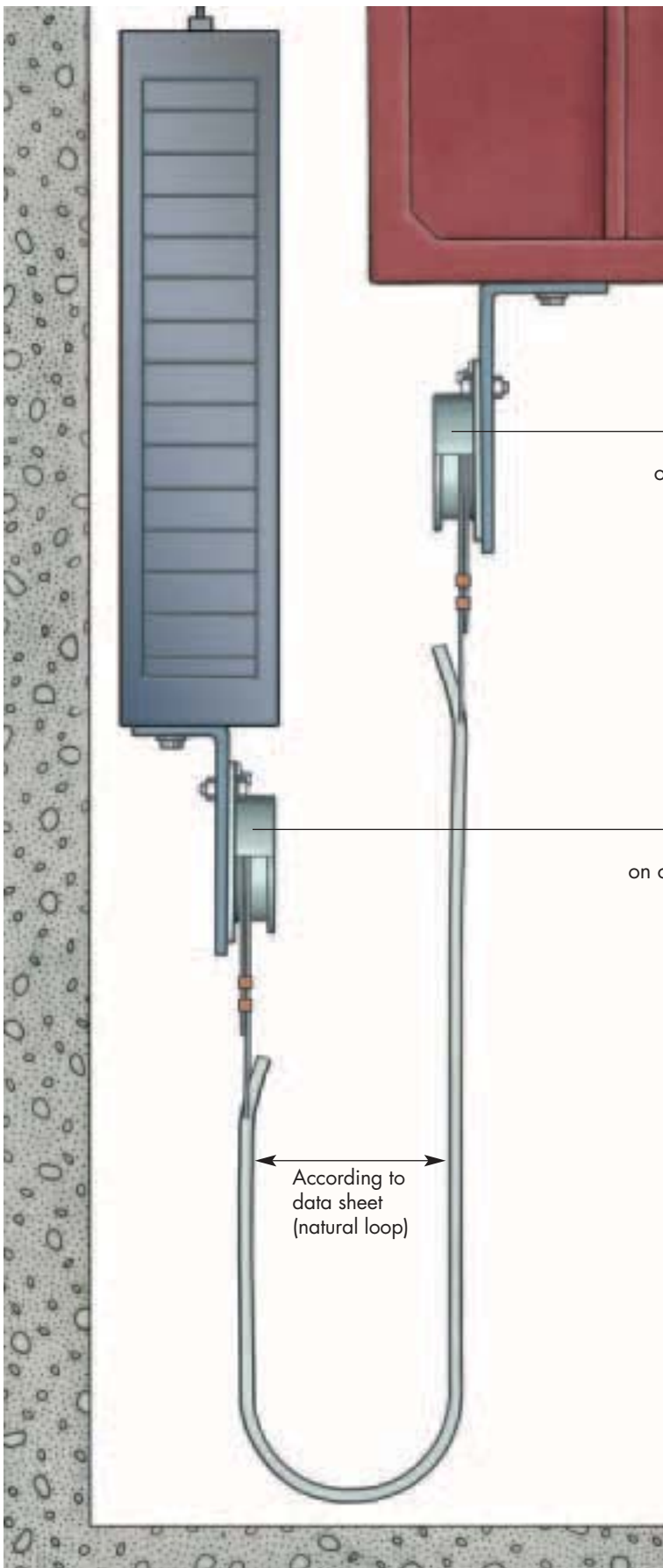

4.10
Installation position of
Compensation weight CW

Free suspension length of maximum
220 mm.

Permissible suspension devices:
LZ 4001

Suspension
on elevator car

Suspension
on counter weight

According to
data sheet
(natural loop)

Accessories

Wire rope cutter (Part No. 184575)

Cuts steel wire ropes
up to dia. 8 mm (0.32 inches)



Stripping knife (Part No. 163358)

Special knife to commence the
removal of the cable jacket



Crimping sleeves on demand



Tool-Box (Part No. 179278) Complete with all tools

Cutter (Part No. 179473)

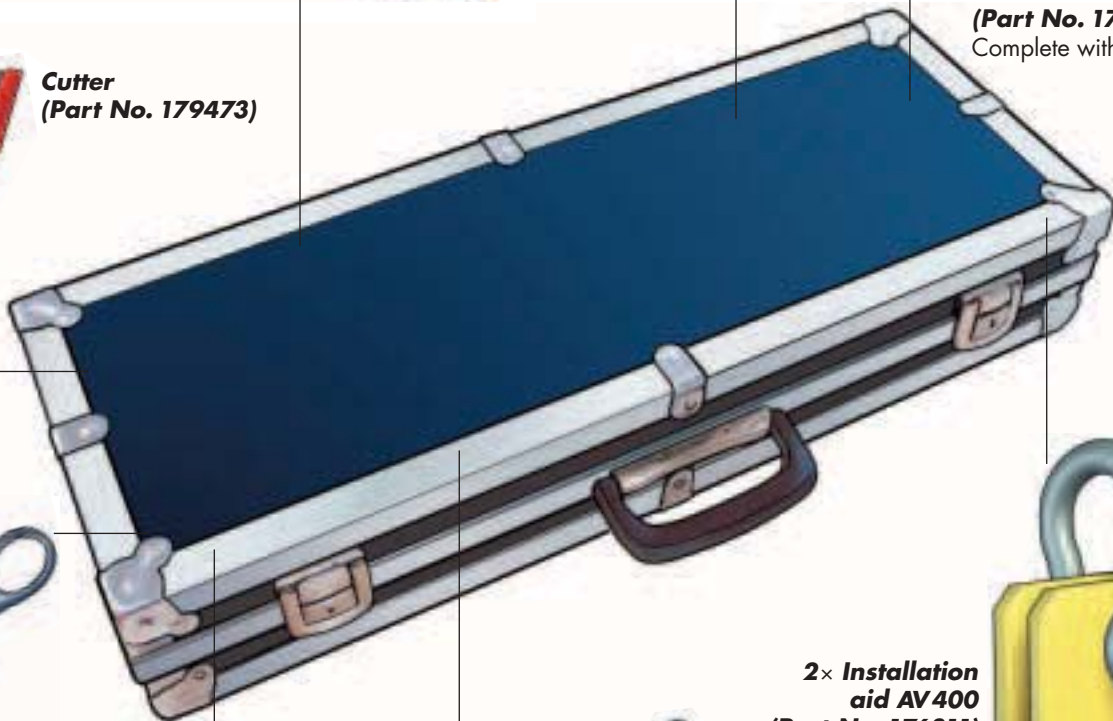

Universal shears (Part No. 179472)

2x Installation aid AV 400 (Part No. 176811)



Steel wire ropes

Crimping tool (Part No. 166667)

Tool for splicing of steel wire
ropes on Dynofil FH cables.





DATWYLER

SWITZERLAND

Dätwyler Cabling Solutions AG

Gotthardstrasse 31
6460 Altdorf, Switzerland
T + 41 41 875-1268
F + 41 41 875-1986
info.cabling.ch@datwyler.com
www.cabling.datwyler.com

GERMANY

Dätwyler Cables GmbH

Auf der Roos 4-12
65795 Hattersheim, Germany
T + 49 6190 8880-0
F + 49 6190 8880-80
info.cabling.de@datwyler.com
www.cabling.datwyler.com

Dätwyler Cables GmbH

Lilienthalstraße 17
85399 Hallbergmoos, Germany
T + 49 811 998633-0
F + 49 811 998633-30
info.cabling.de@datwyler.com
www.cabling.datwyler.com

AUSTRIA

Dätwyler Cables GmbH Office Austria

Tenschertstraße 8
1230 Wien, Austria
T + 43 1 8101641-0
F + 43 1 8101641-35
info.cabling.at@datwyler.com
www.cabling.datwyler.com

GREAT BRITAIN

Datwyler (UK) Ltd

Unit B, Omega Enterprise Park
Electron Way
Chandlers Ford
Hampshire SO53 4SE, Great Britain
T + 44 2380 279-999
F + 44 2380 279-998
info.cabling.uk@datwyler.com
www.cabling.datwyler.com

UNITED ARAB EMIRATES

Daetwyler Middle East FZE

Suite 1004, 10th Floor, IB Tower
Business Bay
P. O. Box 263480
Dubai, UAE
T +971 4 4228129
F +971 4 4228096
info.cabling.ae@datwyler.com
www.cabling.datwyler.com

SAUDI ARABIA

Daetwyler Middle East FZE

Office KSA
Office #101, Alhumaid Center
King Abdul Aziz Street
Riyadh, KSA
T +966 1 2630466
F +966 1 2630466
info.cabling.ae@datwyler.com
www.cabling.datwyler.com

CHINA

Datwyler Cables+Systems (Shanghai) Co. Ltd

Building 16, No. 111,
Kang Qiao Dong Road
Kang Qiao Industrial Zone, Pudong
Shanghai 201319, P. R. China
T + 86 21 6813-0066
F + 86 21 6813-0298
info.cabling.cn@datwyler.com
www.cabling.datwyler.com

Datwyler (Suzhou)

Cabling Systems Co. Ltd

Block 31, 15# Dong Fu Road
Suzhou Singapore Industrial Park
Suzhou 215123, P. R. China
T + 86 512 6265-3600
F + 86 512 6265-3650
harnessing.cabling.cn@datwyler.com
www.cabling.datwyler.com

SINGAPORE

Datwyler (Thelma)

Cables+Systems Pte Ltd

29 Tech Park Crescent
638103 Singapore
T + 65 68631166
F + 65 68978885
info.cabling.sg@datwyler.com
www.cabling.datwyler.com